

DURASTONE

150 HIGGINSON AVENUE - LINCOLN, RI 02865 - Phone (401) 723-7100 - Fax (401) 723-6866

PRECAST CONCRETE CURB

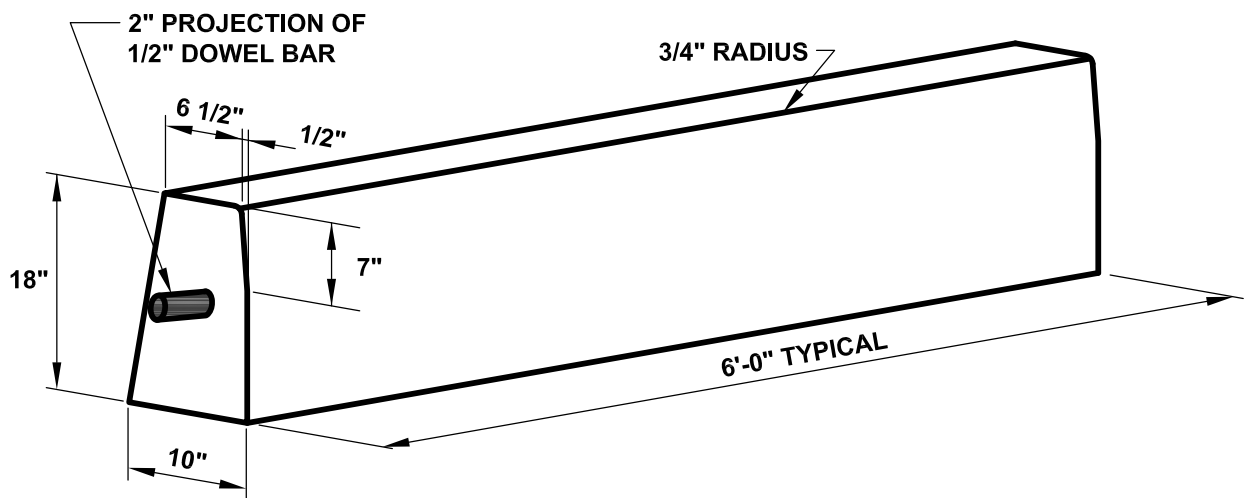

STANDARD SPECIFICATIONS

1. MAXIMUM LENGTHS USING 8' & 10' RADII WITH 90° ANGLE ARE 4'-2" AND 5'-3", RESPECTIVELY
2. MINIMUM LENGTH OF STRAIGHT OR CIRCULAR FILLER SEGMENT IS 4'-0"
3. CIRCULAR CURB USED IN CURVES WITH A RADIUS OF 120' OR LESS. STRAIGHT CURB USED IN CURVES WITH RADIUS GREATER THAN 120'.
4. SMOOTH SPONGE FINISH ON EXPOSED SURFACES
5. 5,000 PSI - ZERO SLUMP PORTLAND CEMENT CONCRETE MIX
6. CONFORMS TO RI STANDARD 7.1.0

DURASTONE

150 HIGGINSON AVENUE - LINCOLN, RI 02865 - Phone (401) 723-7100 - Fax (401) 723-6866

PRECAST CONCRETE RAMP STONE

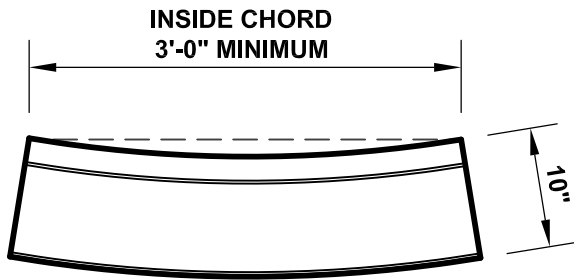

PLAN

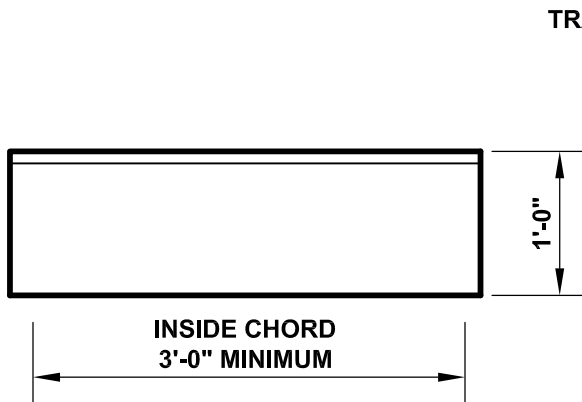

ELEVATION

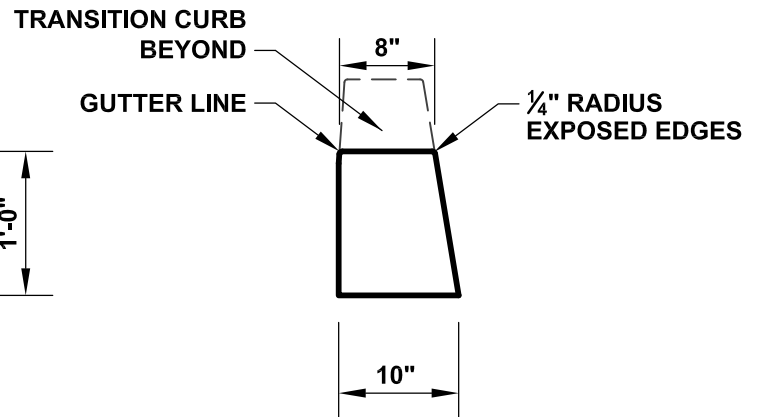

SECTION

STANDARD SPECIFICATIONS

1. EXPOSED SURFACES TO HAVE SMOOTH SPONGE FLOAT FINISH.
2. EXPOSED EDGES RECEIVE 1/4" RADIUS.
3. CONFORMS TO RI STANDARD 7.1.9.
4. WHEELCHAIR RAMP TRANSITION CURBS ARE SEPARATE ITEMS.

DURASTONE

150 HIGGINSON AVENUE - LINCOLN, RI 02865 - Phone (401) 723-7100 - Fax (401) 723-6866

ARC LENGTHS OF CIRCULAR CURB

RADIUS	90° ARC LENGTH	NO. PIECES	LENGTH EACH PIECE	DEC. EQUIV.
2'-0"	3'-1½"	1	3'-1½"	3.125
3'-0"	4'-8½"	1	4'-8½"	4.708
4'-0"	6'-3¾"	2	3'-1¾"	3.135
5'-0"	7'-10¼"	2	3'-11"	3.917
6'-0"	9'-5"	2	4'-8½"	4.708
8'-0"	12'-6¾"	3	4'-2½"	4.208
10'-0"	15'-8½"	3	5'-2¾"	5.229
12'-0"	18'-10⅞"	4	4'-8½"	4.708
15'-0"	23'-6¾"	4	5'-10¼"	5.854
20'-0"	31'-5"	6	5'-2½"	5.208
25'-0"	39'-3 ¼"	8	4'-11"	4.917
30'-0"	47'-1½"	9	5'-2¾"	5.229
40'-0"	62'-5⅞"	10	6'-0"	6.000
50'-0"	78'-6½"	13	6'-0"	6.000
60'-0"	94'-2⅞"	16	6'-0"	6.000
70'-0"	109'-11⅜"	18	6'-0"	6.000
80'-0"	125'-7⅞"	21	6'-0"	6.000
90'-0"	141'-4⅜"	24	6'-0"	6.000
100'-0"	153'-7⅞"	26	6'-0"	6.000
110'-0"	172'-9½"	26	6'-0"	6.000
120'-0"	188'-6"	31	6'-0"	6.000

DURASTONE

150 HIGGINSON AVENUE - LINCOLN, RI 02865 - Phone (401) 723-7100 - Fax (401) 723-6866

6'-0" TRANSITION CURB

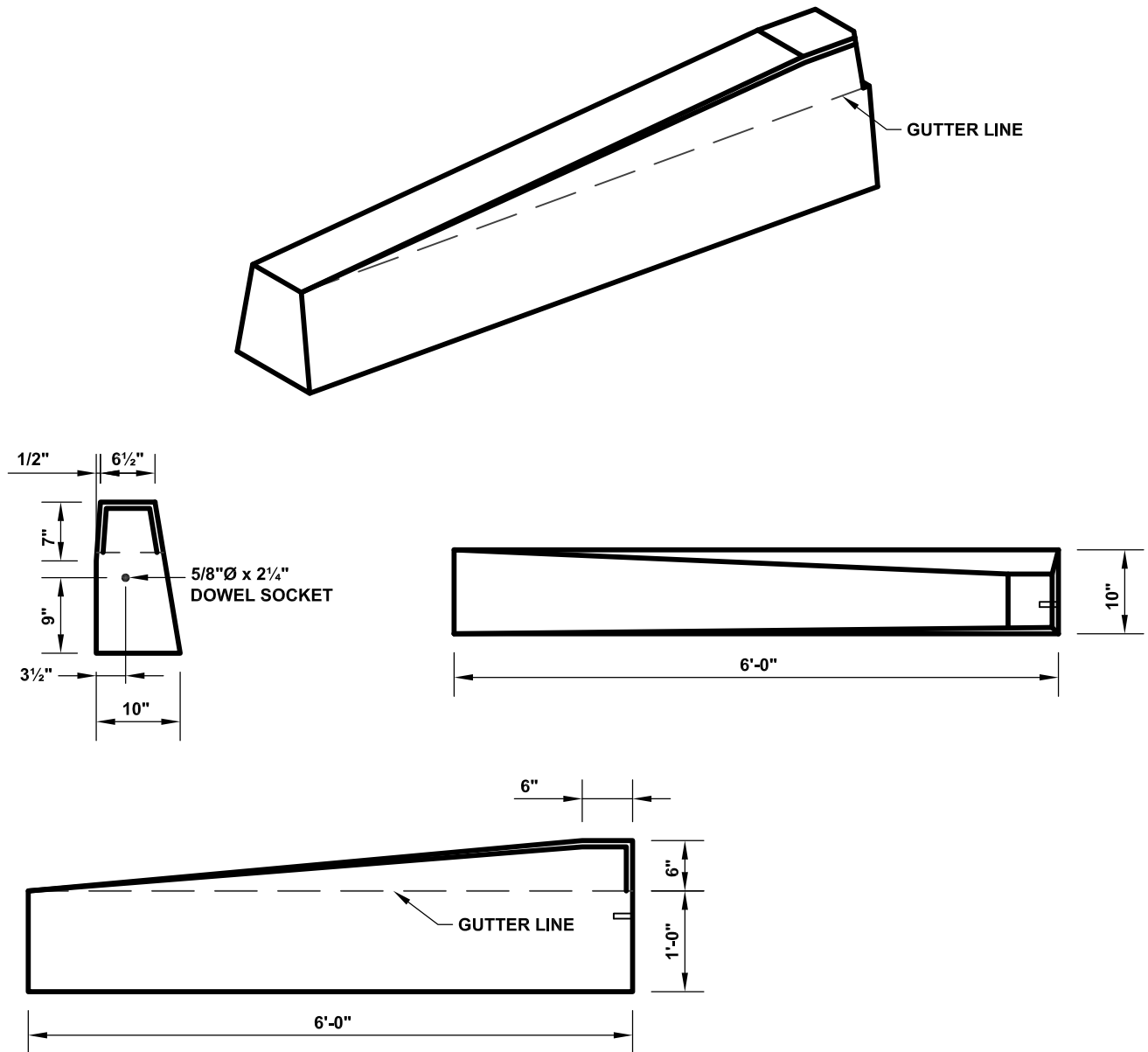

STANDARD SPECIFICATIONS

1. ONE DIRECTION TRANSITION SHOWN. OPP. HAND SIMILAR.
2. EXPOSED SURFACES TO HAVE SMOOTH SPONGE FLOAT FINISH.
3. EXPOSED EDGES RECEIVE 3/4" CHAMFER.
4. 5,000 PSI - ZERO SLUMP PORTLAND CEMENT CONCRETE MIX.
5. CONFORMS TO RI STANDARD 7.1.2.

NPCA
CERTIFIED PLANT

DURASTONE

150 HIGGINSON AVENUE - LINCOLN, RI 02865 - Phone (401) 723-7100 - Fax (401) 723-6866

WHEELCHAIR RAMP TRANSITION CURBS

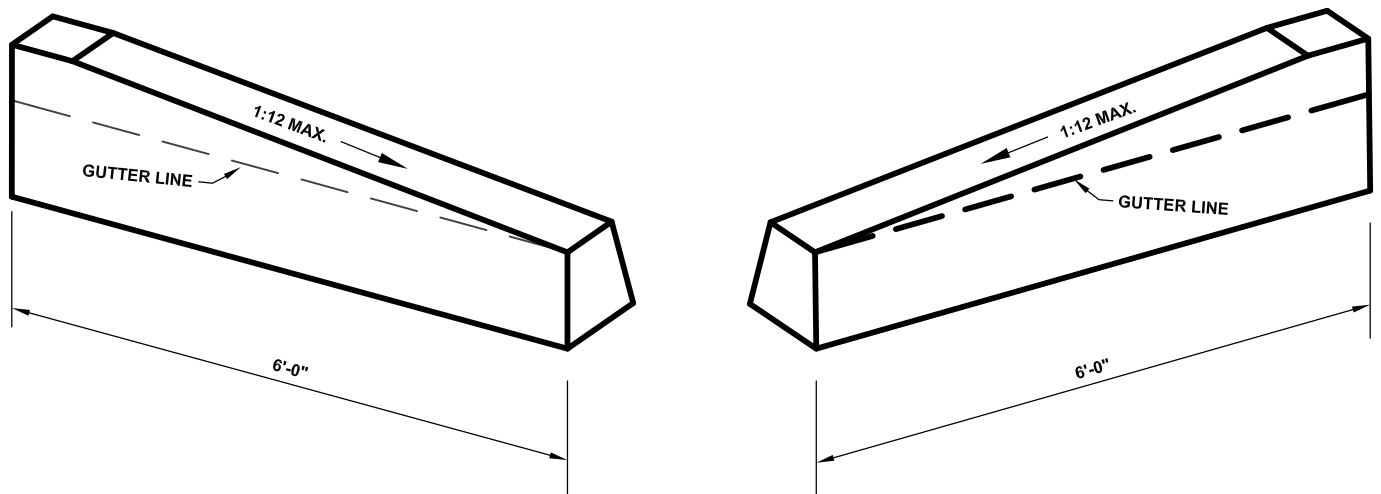

STANDARD SPECIFICATIONS

1. EXPOSED SURFACES TO HAVE SMOOTH SPONGE FLOAT FINISH.
2. EXPOSED EDGES RECEIVE 3/4" CHAMFER.
3. 5,000 PSI - ZERO SLUMP PORTLAND CEMENT CONCRETE MIX.
4. CONFORMS TO RI STANDARD 43.3.0.
5. SPECIFY SLOPE AND LEFT, RIGHT, OR SET.
6. PRECAST CONCRETE RAMP STONE SEPARATE ITEM.

NPCA
CERTIFIED PLANT

DURASTONE

150 HIGGINSON AVENUE - LINCOLN, RI 02865 - Phone (401) 723-7100 - Fax (401) 723-6866

2'-0" RADIUS CORNER

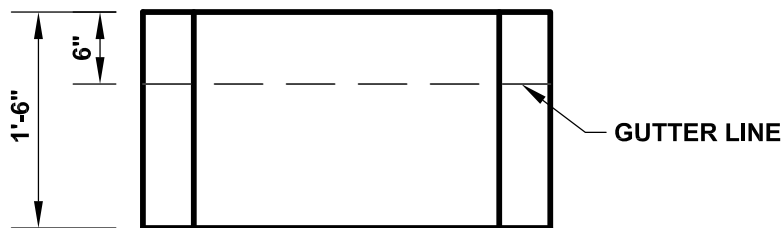
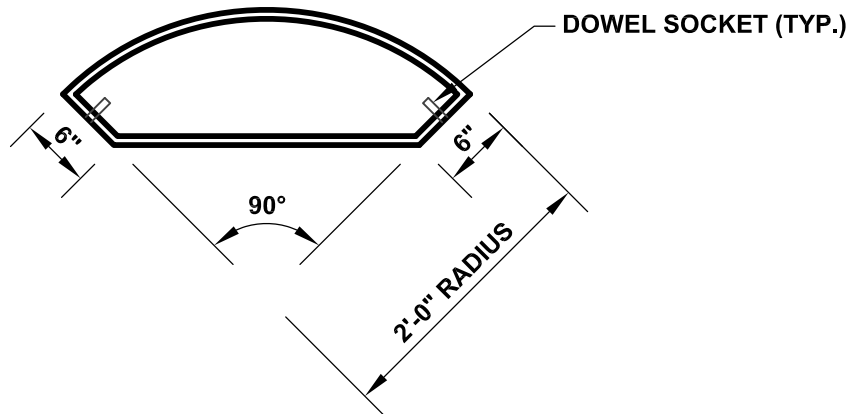
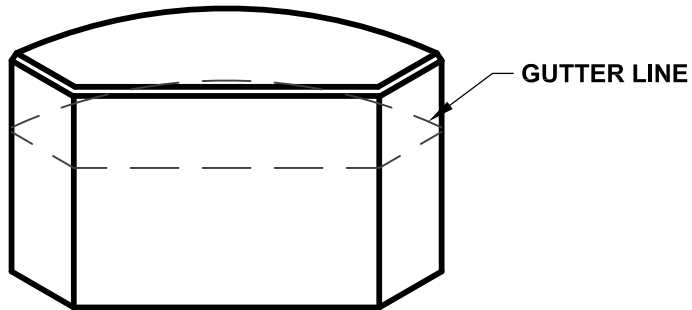

STANDARD SPECIFICATIONS

1. EXPOSED SURFACES TO HAVE SMOOTH SPONGE FLOAT FINISH.
2. EXPOSED EDGES RECEIVE 3/4" CHAMFER.
3. 5,000 PSI - ZERO SLUMP PORTLAND CEMENT CONCRETE MIX.
4. CONFORMS TO RI STANDARD 7.1.4.

DURASTONE

150 HIGGINSON AVENUE - LINCOLN, RI 02865 - Phone (401) 723-7100 - Fax (401) 723-6866

3'-0" TRANSITION CURB

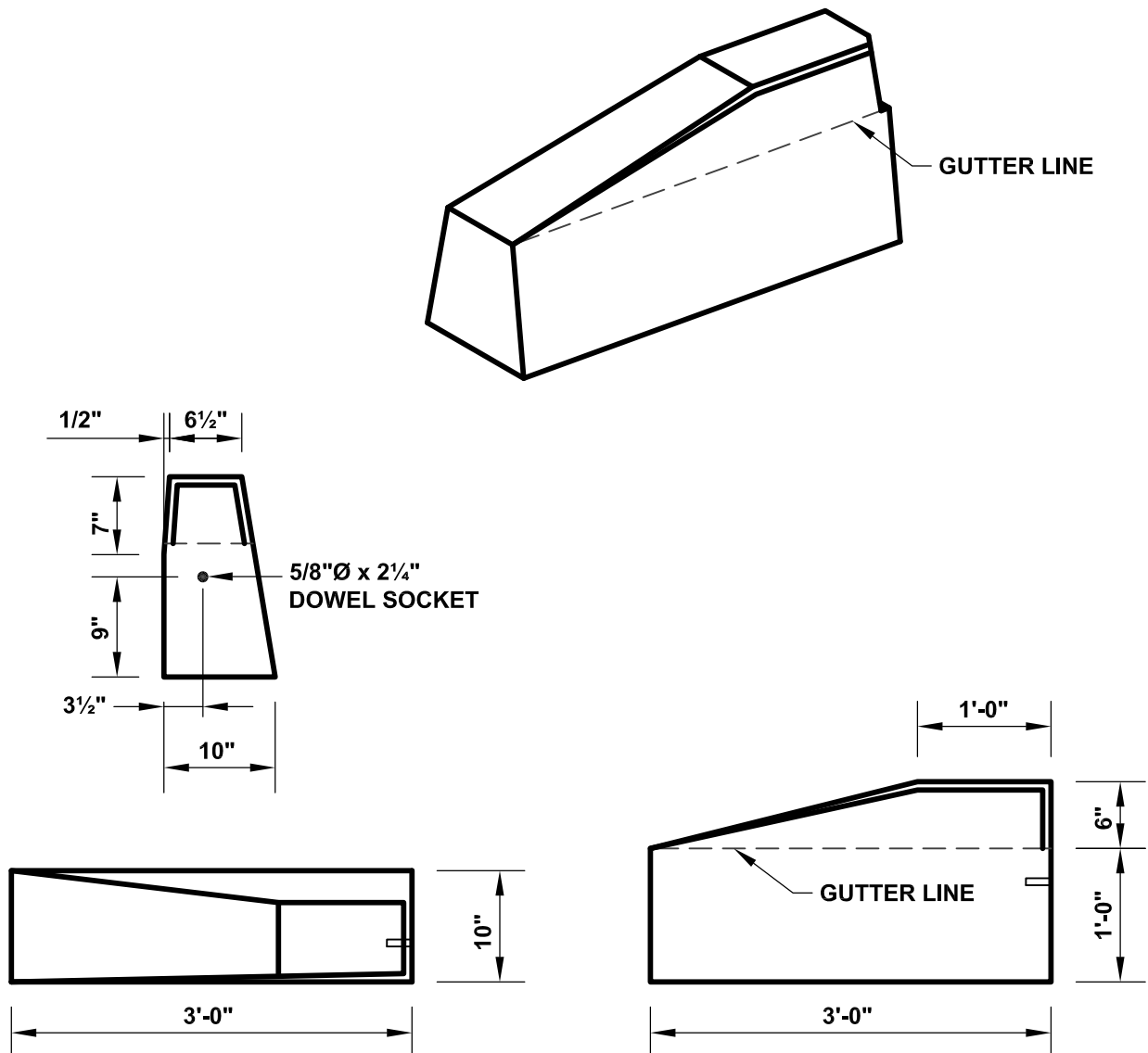

STANDARD SPECIFICATIONS

1. ONE DIRECTION TRANSITION SHOWN. OPP. HAND SIMILAR.
2. EXPOSED SURFACES TO HAVE SMOOTH SPONGE FLOAT FINISH.
3. EXPOSED EDGES RECEIVE 3/4" CHAMFER.
4. 5,000 PSI - ZERO SLUMP PORTLAND CEMENT CONCRETE MIX.
5. CONFORMS TO RI STANDARD 7.1.1.

DURASTONE

150 HIGGINSON AVENUE - LINCOLN, RI 02865 - Phone (401) 723-7100 - Fax (401) 723-6866

PRECAST CONCRETE CURB SLOPE FACED

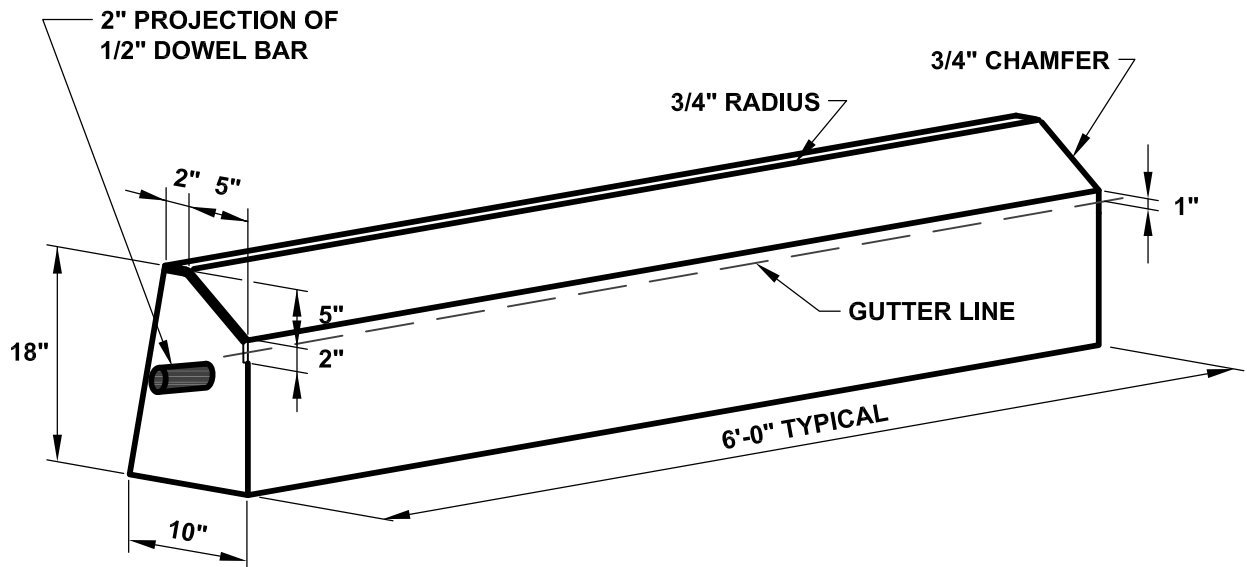

STANDARD SPECIFICATIONS

1. MAXIMUM LENGTHS USING 8' & 10' RADII WITH 90° ANGLE ARE 4'-2" AND 5'-3", RESPECTIVELY.
2. MINIMUM LENGTH OF STRAIGHT OR CIRCULAR FILLER SEGMENT IS 4'-0".
3. CIRCULAR CURB USED IN CURVES WITH A RADIUS OF 120' OR LESS. STRAIGHT CURB USED IN CURVES WITH RADIUS GREATER THAN 120'.
4. SMOOTH SPONGE FINISH ON EXPOSED SURFACES.
5. 5,000 PSI - ZERO SLUMP PORTLAND CEMENT CONCRETE MIX.
6. CONFORMS TO RI STANDARD 7.2.0

DURASTONE

150 HIGGINSON AVENUE - LINCOLN, RI 02865 - Phone (401) 723-7100 - Fax (401) 723-6866

SLOPED FACE TRANSITION CURB

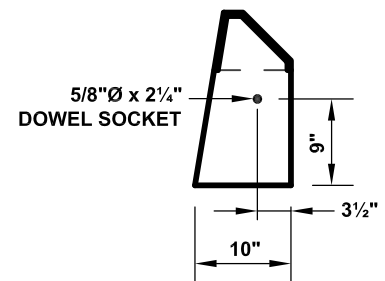
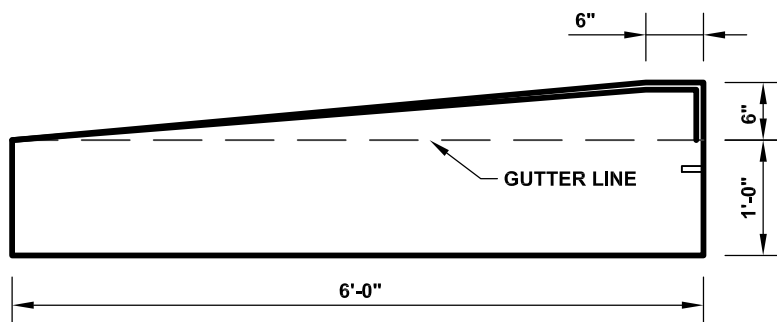
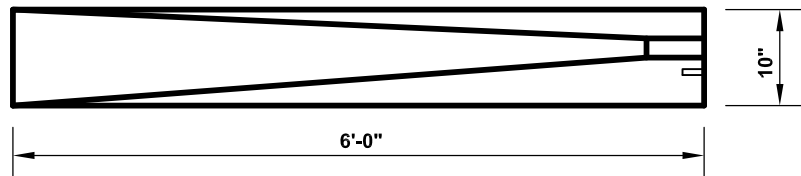
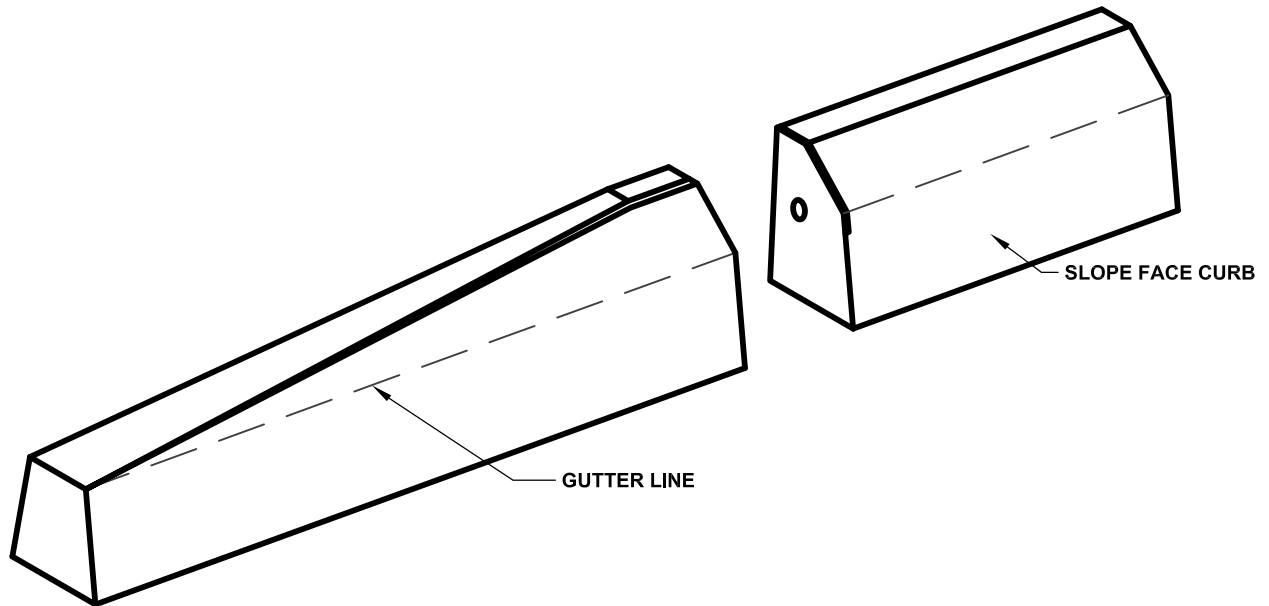

STANDARD SPECIFICATIONS

1. ONE DIRECTION TRANSITION SHOWN. OPP. HAND SIMILAR.
2. EXPOSED SURFACES TO HAVE SPONGE FLOAT FINISH.
3. EXPOSED EDGES RECEIVE 3/4" CHAMFER.
4. 5,000 PSI - ZERO SLUMP PORTLAND CEMENT CONCRETE MIX.
5. CONFORMS TO RI STANDARD 7.2.1.

NPCA
CERTIFIED PLANT

DURASTONE

150 HIGGINSON AVENUE - LINCOLN, RI 02865 - Phone (401) 723-7100 - Fax (401) 723-6866

VERTICAL FACE TO SLOPE FACE TRANSITION CURB

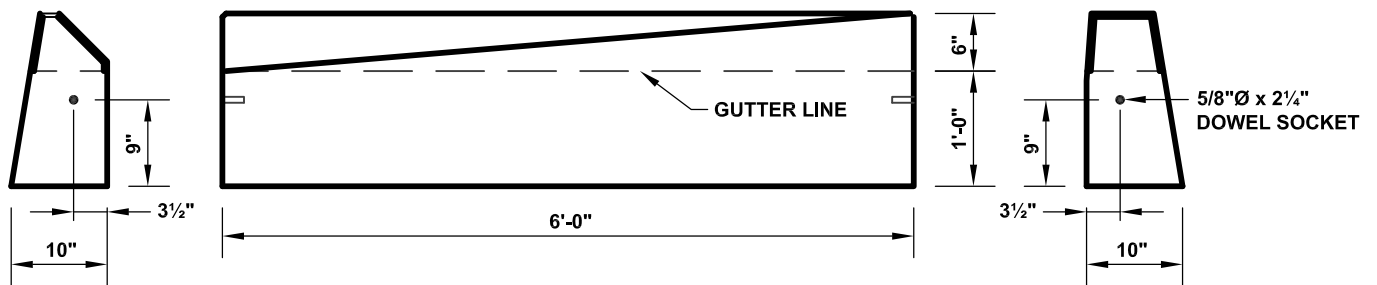
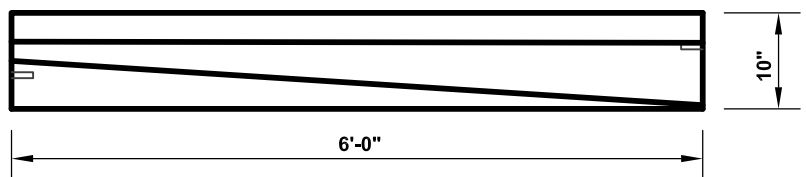
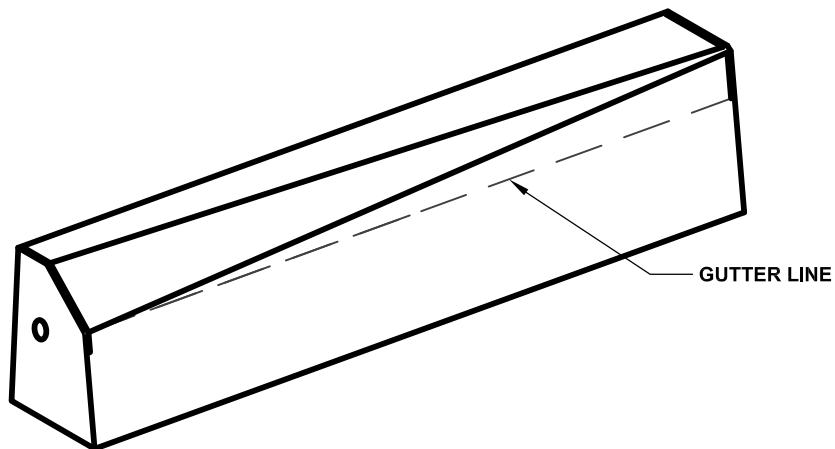

STANDARD SPECIFICATIONS

1. ONE DIRECTION TRANSITION SHOWN. OPP. HAND SIMILAR.
2. EXPOSED SURFACES TO HAVE SPONGE FLOAT FINISH.
3. EXPOSED EDGES RECEIVE 3/4" CHAMFER.
4. 5,000 PSI - ZERO SLUMP PORTLAND CEMENT CONCRETE MIX.
5. CONFORMS TO RI STANDARD 7.2.2.

NPCA
CERTIFIED PLANT

DURASTONE

150 HIGGINSON AVENUE - LINCOLN, RI 02865 - Phone (401) 723-7100 - Fax (401) 723-6866

CONCRETE PARK CURB

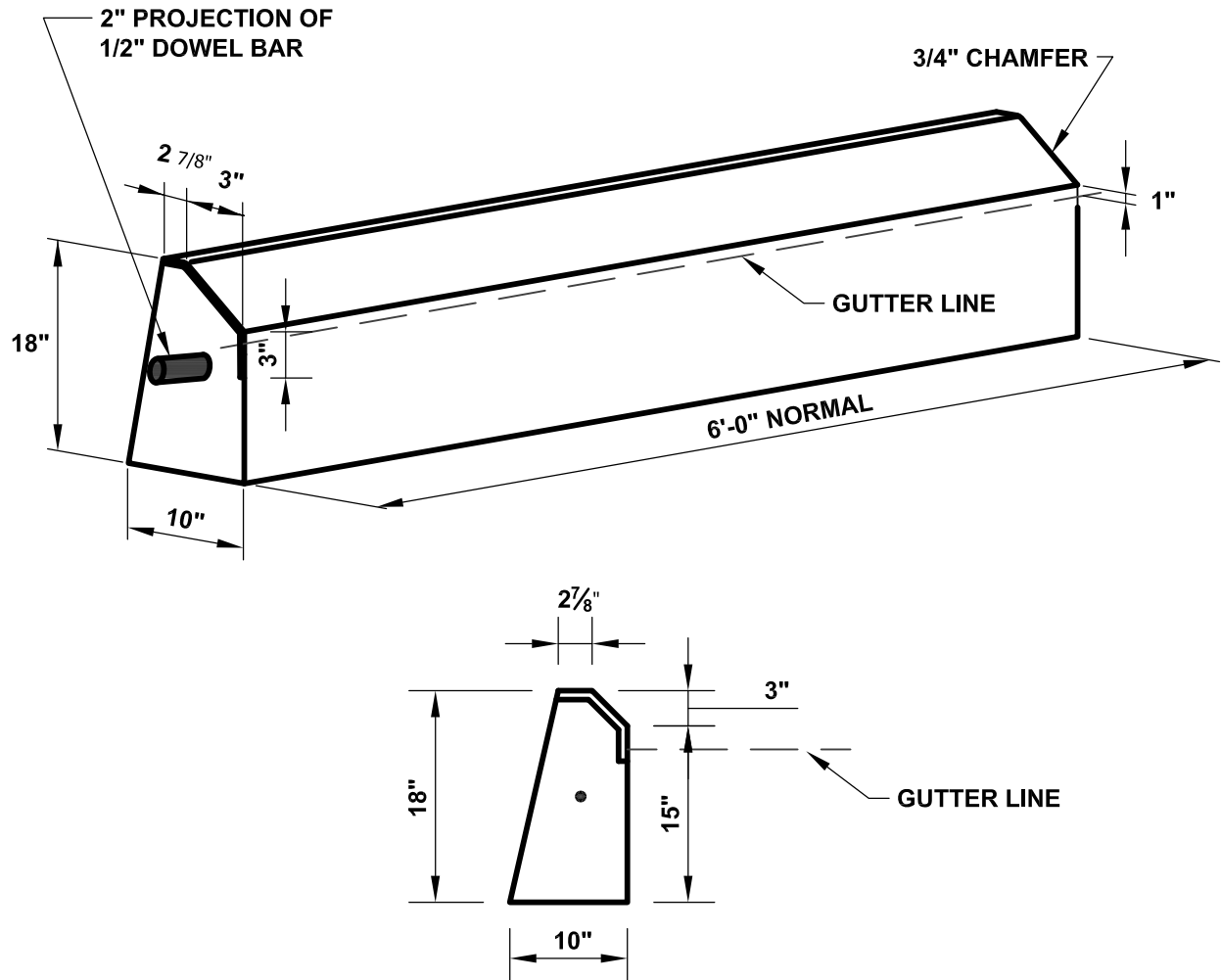

STANDARD SPECIFICATIONS

1. MINIMUM LENGTH OF STRAIGHT OR CIRCULAR FILLER PIECES ARE 4'-0".
2. EXPOSED SURFACES TO HAVE SMOOTH SPONGE FINISH.
3. CIRCULAR CURB USED IN CURVES WITH A RADIUS OF 120' OR LESS. STRAIGHT CURB USED IN CURVES WITH RADIUS GREATER THAN 120'.
4. 5,000 PSI - ZERO SLUMP PORTLAND CEMENT CONCRETE MIX.

DURASTONE

150 HIGGINSON AVENUE - LINCOLN, RI 02865 - Phone (401) 723-7100 - Fax (401) 723-6866

38" APRON STONE

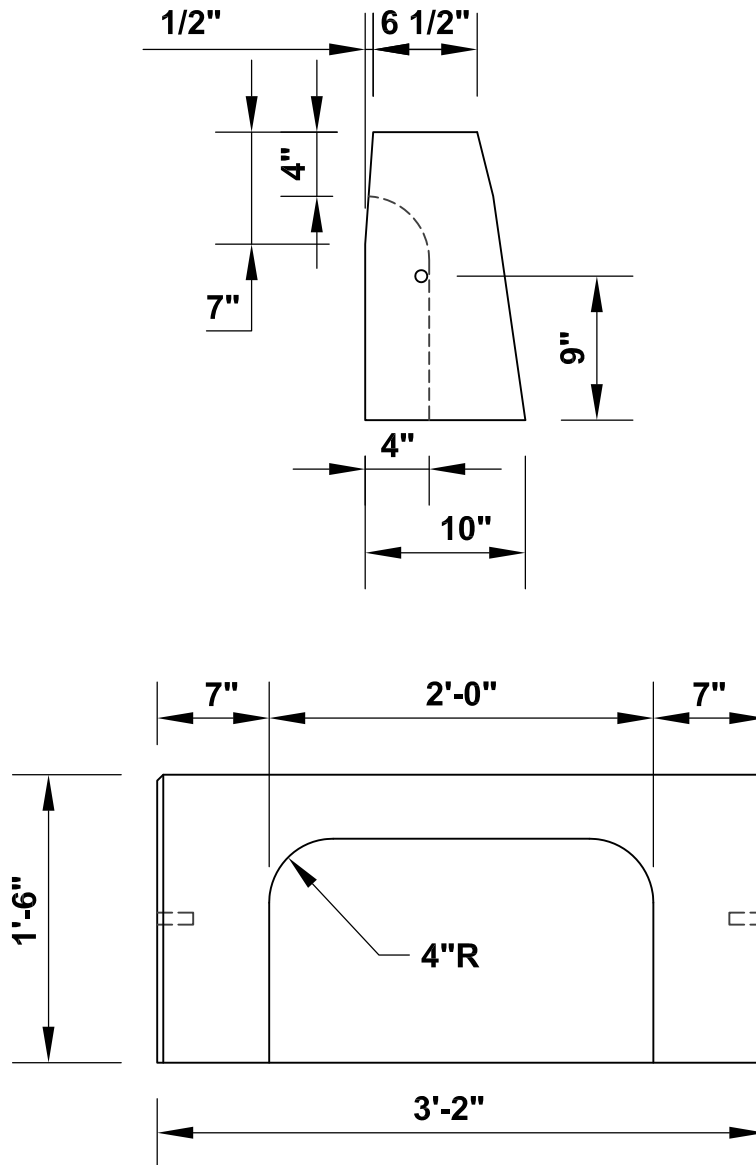

APPROX. WEIGHT: 400 LB

STANDARD SPECIFICATIONS

1. EXPOSED SURFACES TO HAVE SMOOTH SPONGE FINISH.
2. EXPOSED EDGES RECEIVE 3/4" CHAMFER.
3. 5,000 PSI - ZERO SLUMP PORTLAND CEMENT CONCRETE MIX.
4. CONFORMS TO RI STANDARD 7.1.8.

DURASTONE

150 HIGGINSON AVENUE - LINCOLN, RI 02865 - Phone (401) 723-7100 - Fax (401) 723-6866

5' APRON STONE

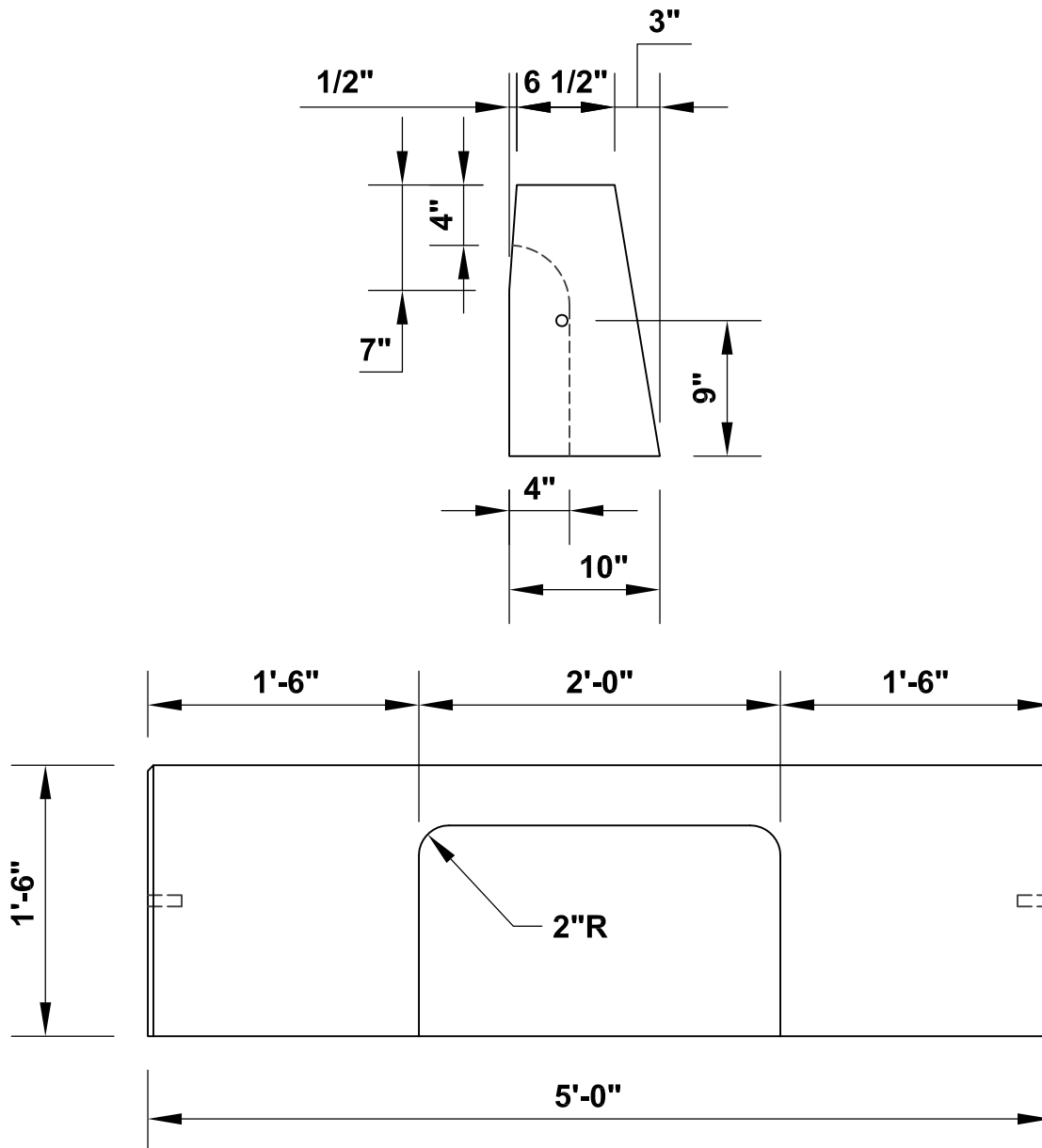

APPROX. WEIGHT: 700 LB

STANDARD SPECIFICATIONS

1. EXPOSED SURFACES TO HAVE SMOOTH SPONGE FINISH.
2. EXPOSED EDGES RECEIVE 3/4" CHAMFER.
3. 5,000 PSI - ZERO SLUMP PORTLAND CEMENT CONCRETE MIX.
4. CONFORMS TO RI STANDARD 7.1.7.

NPCA
CERTIFIED PLANT

DURASTONE

150 HIGGINSON AVENUE - LINCOLN, RI 02865 - Phone (401) 723-7100 - Fax (401) 723-6866

6' APRON STONE

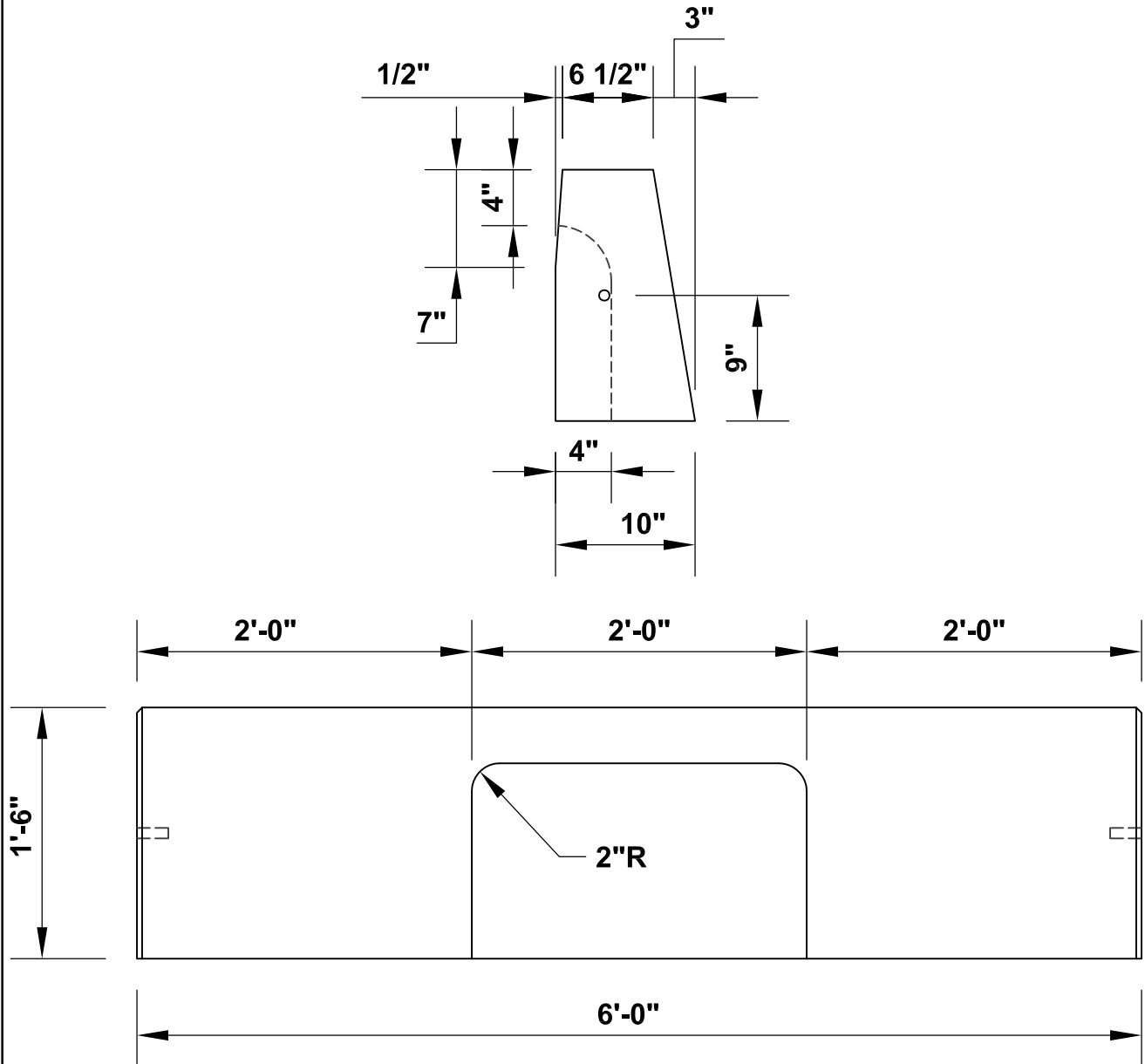

APPROX. WEIGHT: 860 LB

STANDARD SPECIFICATIONS

1. EXPOSED SURFACES TO HAVE SMOOTH SPONGE FINISH.
2. EXPOSED EDGES RECEIVE 3/4" CHAMFER.
3. 5,000 PSI - ZERO SLUMP PORTLAND CEMENT CONCRETE MIX.
4. CONFORMS TO RI STANDARD 7.1.7.

NPCA
CERTIFIED PLANT

DURASTONE

150 HIGGINSON AVENUE - LINCOLN, RI 02865 - Phone (401) 723-7100 - Fax (401) 723-6866

6' DOUBLE APRON STONE

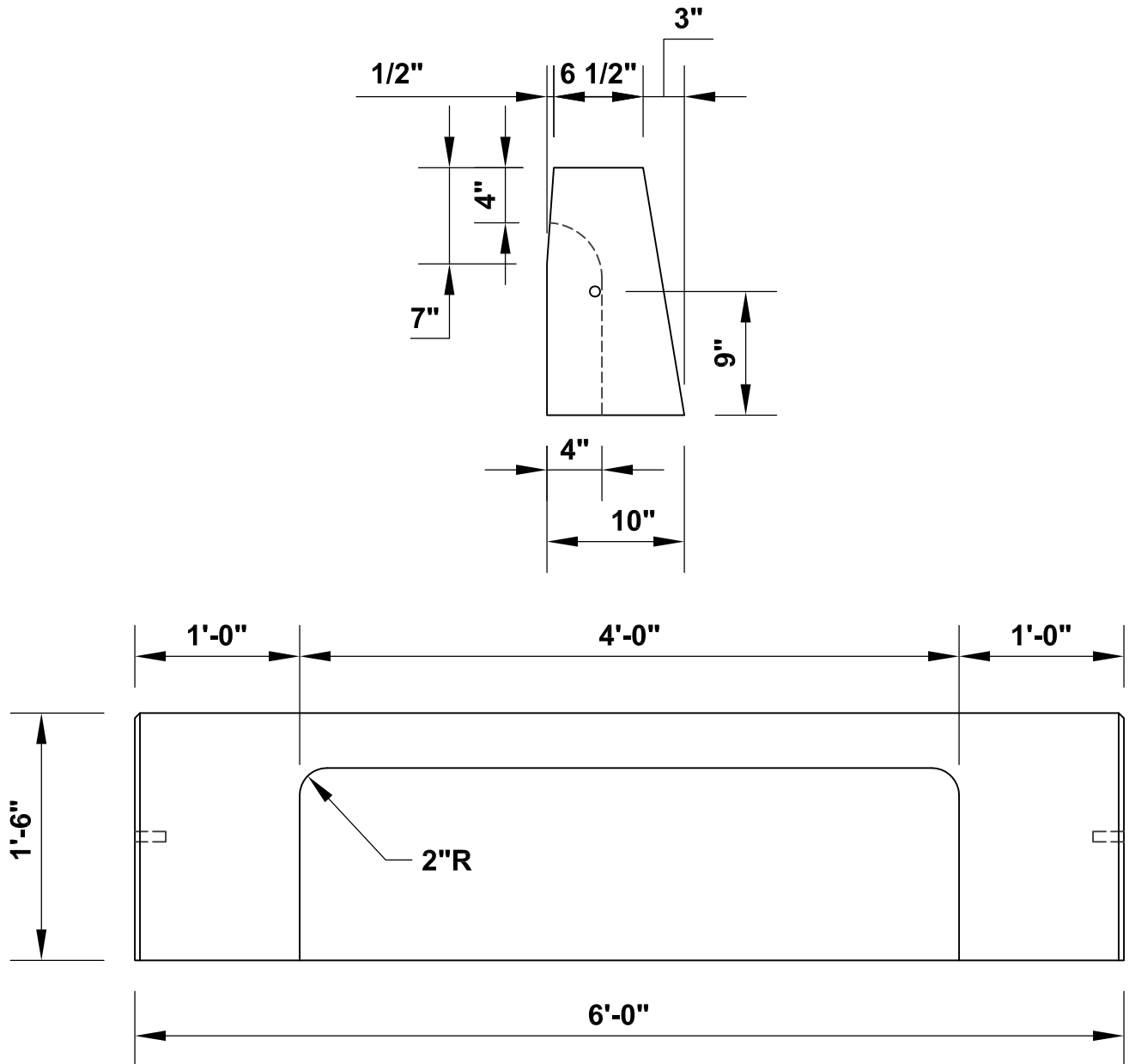

APPROX. WEIGHT: 700 LB

STANDARD SPECIFICATIONS

1. EXPOSED SURFACES TO HAVE SMOOTH SPONGE FINISH.
2. EXPOSED EDGES RECEIVE 3/4" CHAMFER.
3. 5,000 PSI - ZERO SLUMP PORTLAND CEMENT CONCRETE MIX.
4. CONFORMS TO RI STANDARD 7.1.7.M

NPCA
CERTIFIED PLANT

DURASTONE

150 HIGGINSON AVENUE - LINCOLN, RI 02865 - Phone (401) 723-7100 - Fax (401) 723-6866

38" INLET STONE

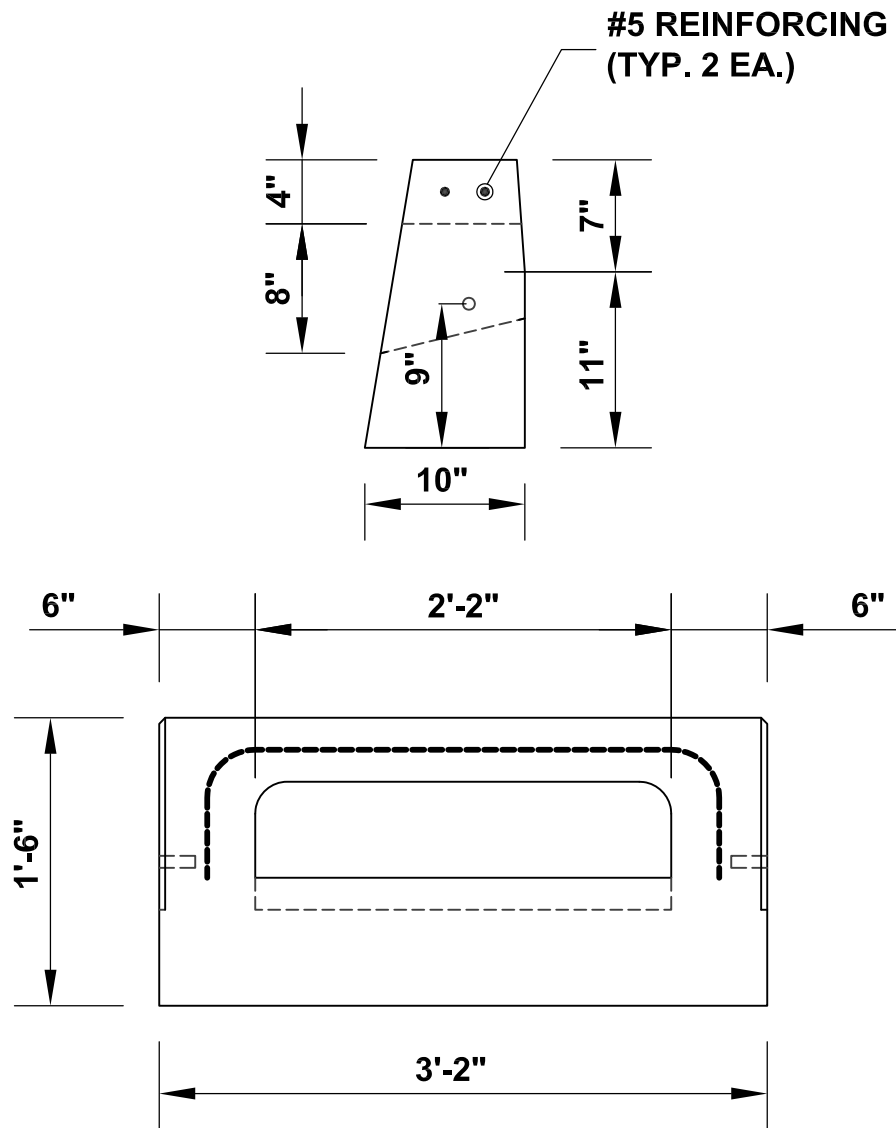

APPROX. WEIGHT: 400 LB

STANDARD SPECIFICATIONS

1. EXPOSED SURFACES TO HAVE SMOOTH SPONGE FINISH.
2. EXPOSED EDGES RECEIVE 3/4" CHAMFER.
3. 5,000 PSI - ZERO SLUMP PORTLAND CEMENT CONCRETE MIX.
4. CONFORMS TO RI STANDARD 7.1.6.

NPCA
CERTIFIED PLANT

DURASTONE

150 HIGGINSON AVENUE - LINCOLN, RI 02865 - Phone (401) 723-7100 - Fax (401) 723-6866

5' INLET STONE

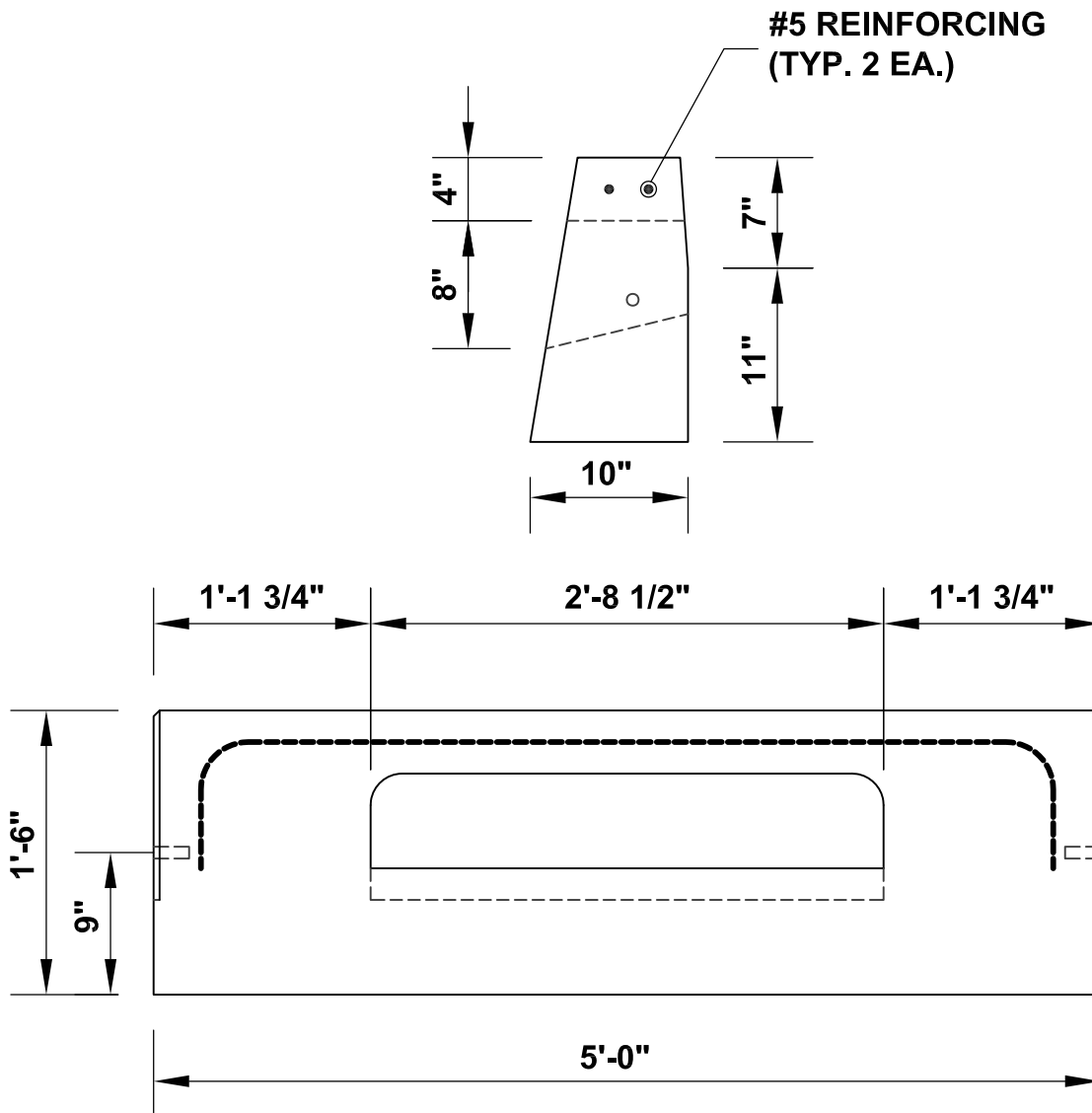

APPROX. WEIGHT: 650 LB

STANDARD SPECIFICATIONS

1. EXPOSED SURFACES TO HAVE SMOOTH SPONGE FINISH.
2. EXPOSED EDGES RECEIVE 3/4" CHAMFER.
3. 5,000 PSI - ZERO SLUMP PORTLAND CEMENT CONCRETE MIX.
4. CONFORMS TO RI STANDARD 7.1.5.

NPCA
CERTIFIED PLANT

DURASTONE

150 HIGGINSON AVENUE - LINCOLN, RI 02865 - Phone (401) 723-7100 - Fax (401) 723-6866

6' INLET STONE

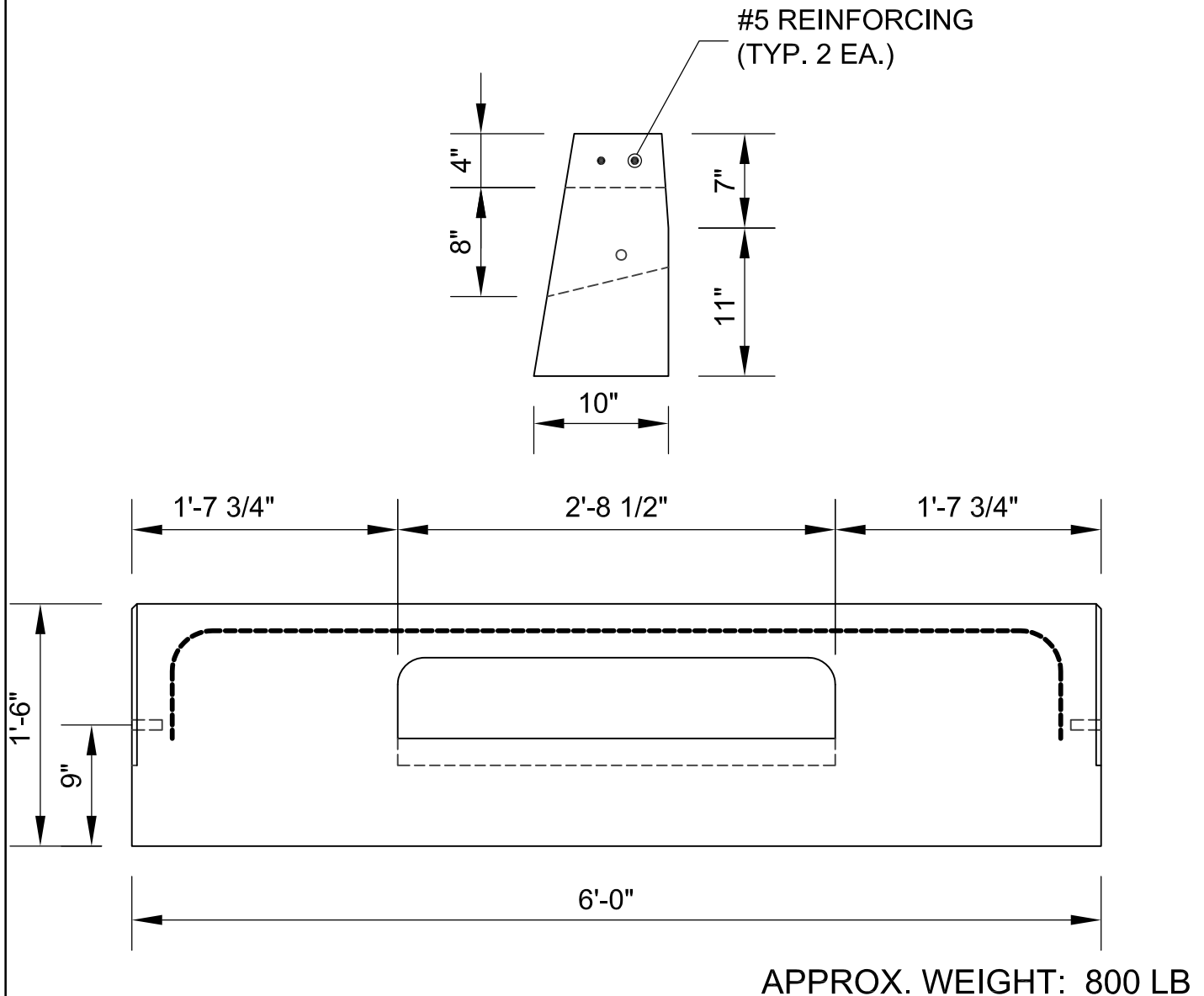

STANDARD SPECIFICATIONS

1. EXPOSED SURFACES TO HAVE SMOOTH SPONGE FINISH.
2. EXPOSED EDGES RECEIVE 3/4" CHAMFER.
3. 5,000 PSI - ZERO SLUMP PORTLAND CEMENT CONCRETE MIX.
4. CONFORMS TO RI STANDARD 7.1.5.

DURASTONE

150 HIGGINSON AVENUE - LINCOLN, RI 02865 - Phone (401) 723-7100 - Fax (401) 723-6866

PRECAST LOT CURB

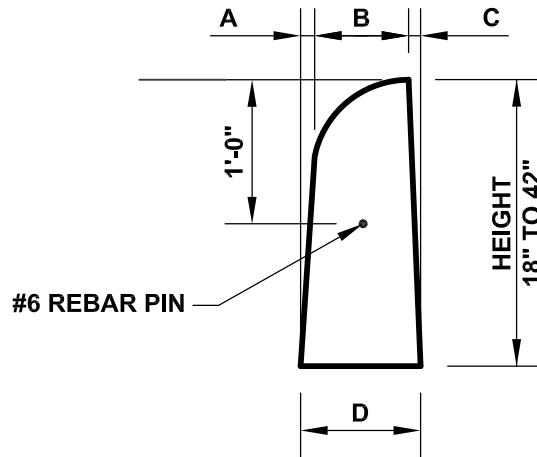

STANDARD DIMENSIONS

HEIGHT	A	B	C	D
18"	1"	8"	1"	10"
24"	1"	8"	1"	10"
30"	1"	8"	3"	12"
36"	1"	8"	5"	14"
42"	1"	8"	9"	18"

STANDARD SPECIFICATIONS

1. EXPOSED SURFACES TO HAVE SMOOTH FORM FINISH
2. MANUFACTURED IN STRAIGHT LENGTHS ONLY.
3. 4,000 PSI CLASS XX(AE) PORTLAND CEMENT CONCRETE.
4. CONFORMS TO RI STANDARD 7.2.3.

DURASTONE

150 HIGGINSON AVENUE - LINCOLN, RI 02865 - Phone (401) 723-7100 - Fax (401) 723-6866

CAR STOPS

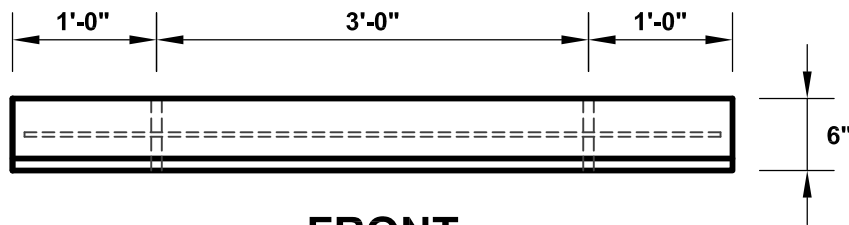
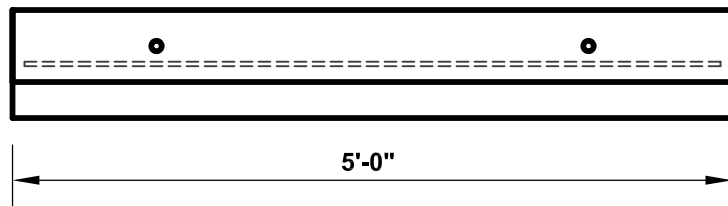
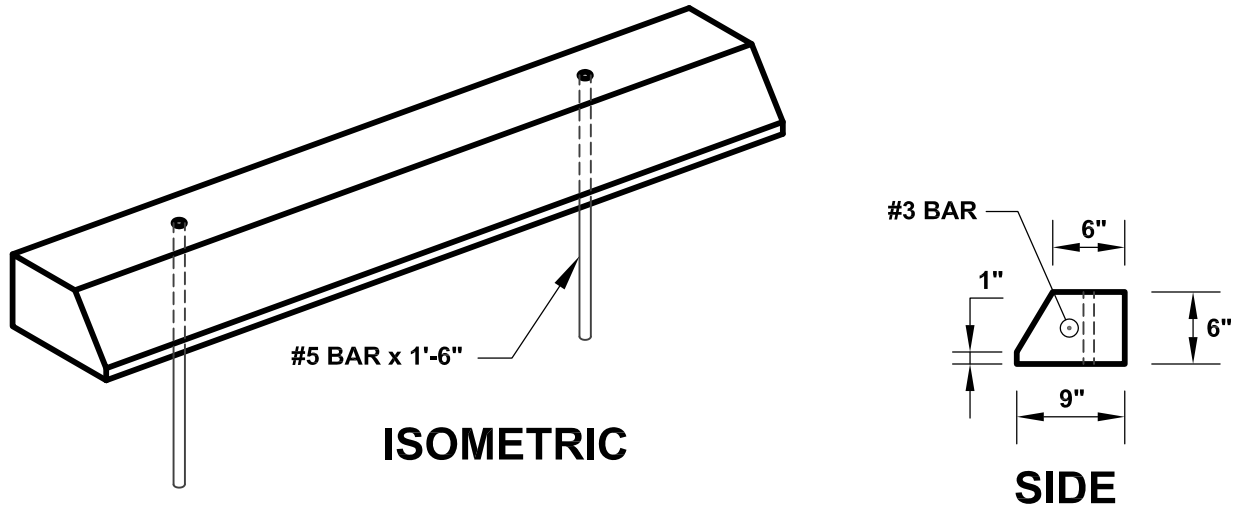

STANDARD SPECIFICATIONS

1. EXPOSED SURFACES TO HAVE SMOOTH FORM FINISH.
2. EXPOSED EDGES RECEIVE 3/4" CHAMFER.
3. 4,000 PSI - CLASS XX(AE) PORTLAND CEMENT CONCRETE MIX.
4. CONFORMS TO RI STANDARD 7.2.4.